

MEASURING PINS



Features

- Manufactured as per IS : 11103:1984
- Measuring pins are manufactured from high quality Alloy Steel & are sub-zero treated for dimensional stability
- Hardened, ground & lapped measuring pins are available in standard steps of 0.01, 0.02, 0.05, 0.10mm
- Length of measuring pins up to dia. 1.49 mm is 40 mm & above dia. 1.50 mm is 50 mm
- Pin sizes from dia. 3.00 mm onwards are marked on diameter
- Pins in a set from 0.50 mm to 2.99 mm supplied with Plastic Container with size separator.
- Loose pins from 0.50 to 20.00 mm supplied with Plastic Container
- Loose pins or pins of odd sizes are available on request
- Pin sets & loose pins supplied with Aluminium Knobs on request
- Non-standard /Customised sets are also supplied on request at extra cost
- Handles & Collets are available on request at extra cost
- Calibration Certificate traceable to National/International standards
- Surface Finish 0.1 $\mu\text{m Ra}$
- Hardness 700 HV

Technical Specifications

Accuracy Grade	Diametrical Tolerance	Geometrical Tolerance	
		Taper (μm)	Circularity (μm)
1	$\pm 0.001 \text{ mm}$	0.5	0.5
2	$\pm 0.002 \text{ mm}$	0.5	1

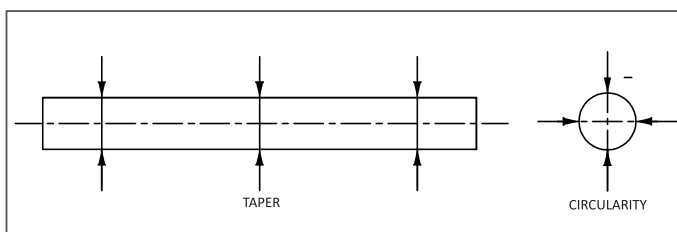

Step 0.01 mm

Measuring Pins Standard Set



Ranges in mm	No. of Pins	Ranges in mm	No. of Pins	Ranges in mm	No. of Pins
0.5 - 1.00	51	13.01 - 14.00	100	21.01 - 21.50	50
1.01 - 2.00	100	14.01 - 15.00	100	21.51 - 22.00	50
2.01 - 3.00	100	15.01 - 16.00	100	22.01 - 22.40	40
3.01 - 4.00	100	16.01 - 16.50	50	22.41 - 22.80	40
4.01 - 5.00	100	16.51 - 17.00	50	22.81 - 23.20	40
5.01 - 6.00	100	17.01 - 17.50	50	23.21 - 23.60	40
6.01 - 7.00	100	17.51 - 18.00	50	23.61 - 24.00	40
7.01 - 8.00	100	18.01 - 18.50	50	24.01 - 24.25	25
8.01 - 9.00	100	18.51 - 19.00	50	24.26 - 24.50	25
9.01 - 10.00	100	19.01 - 19.50	50	24.51 - 24.75	25
10.01 - 11.00	100	19.51 - 20.00	50	24.76 - 25.00	25
11.01 - 12.00	100	20.01 - 20.50	50		
12.01 - 13.00	100	20.51 - 21.00	50		

Step 0.02 mm

Ranges in mm	No. of Pins	Ranges in mm	No. of Pins	Ranges in mm	No. of Pins
0.50 - 2.00	76	12.02 - 14.00	100	20.02 - 21.00	50
2.02 - 4.00	100	14.02 - 16.00	100	21.02 - 22.00	50
4.02 - 6.00	100	16.02 - 17.00	50	22.02 - 22.80	40
6.02 - 8.00	100	17.02 - 18.00	50	22.82 - 23.60	40
8.02 - 10.00	100	18.02 - 19.00	50	23.62 - 24.40	40
10.02 - 12.00	100	19.02 - 20.00	50	24.42 - 25.00	30

Step 0.05 mm

Ranges in mm	No. of Pins	Ranges in mm	No. of Pins	Ranges in mm	No. of Pins
1.00 - 4.00	61	12.05 - 16.00	80	20.05 - 22.50	50
4.05 - 8.00	80	16.05 - 18.00	40	22.55 - 25.00	50
8.05 - 12.00	80	18.05 - 20.00	40		

Step 0.10 mm

Ranges in mm	No. of Pins	Ranges in mm	No. of Pins	Ranges in mm	No. of Pins
0.50 to 1.00	6	2.10 to 10.00	80	15.10 to 18.00	30
1.10 to 2.00	10	10.10 to 15.00	50	18.10 to 20.00	20

Note : For 50mm length series - Measuring length of the pin will be 40 mm from dia. 0.5 to 1.49 mm. and from Dia.1.49 mm onwards it will be 50 mm.

* Pin set with 50 nos pins is also available.



Application

Measuring Pins for checking of bores, center distances, groove dimensions, inspection of micrometers, gear measurements etc.

- Adjusting of dial gauges
- Center to center distance
- Dovetail guide
- Checking of groove dimensions
- Parallel guides
- Depths of profiles and angles
- Straightness of holes
- Angularity and hole tolerance
- Inspection of micrometer
- Measuring width of Slot
- Measuring run out of Chuck
- Measuring eccentricity of Hole

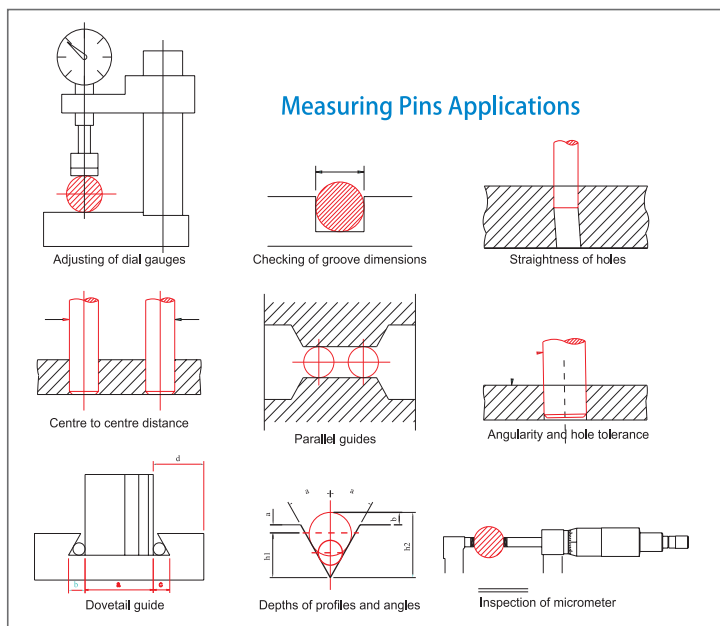

Handles & Collets

- Laser marked, Atraccve Anodised, Light weight handles & Collets are available on request.
 - Smooth & firm clamping of pins in Handles & Collets makes measurements easy
 - Handles & Collect sets are available as follows
 - Loose Handle & Collect with pins as well as without pins are also available
- (ref.below chart for new pin set ranges (in step of 0.01 mm))



Sr. No.	Pin Set Range	Handle Code (per set 1 pc. each)	Collets (for Go + No Go) per set
1	0.5 -1.00	1W	8
2	1.01-2.00	1W	16
		2W	2
3	2.01 - 3.00	2W	14
4	3.01-4.00	2W	12
5	4.01-5.00	2W	8
		3W	6
6	5.01-6.00	3W	12
7	6.01 - 7.00	3W	10
8	7.01-8.00	3W	2
		4W	8
9	8.01-9.00	4W	10
10	9.01-10.00	4W	8
11	10.01-11.00	4W	4
		5W	6
12	11.01-12.00	5W	8
13	12.01-13.00	5W	6
		6W	2
14	13.01-14.00	6W	6
15	14.01-15.00	6W	6
16	15.01-16.00	6W	8
17	16.01-16.50	6W	2
		7W	2
18	16.51 - 17.00	7W	4
19	17.01 -17.50	7W	6
20	17.51-18.00	7W	4
21	18.01-18.50	7W	4
22	18.51 - 19.00	7W	4
23	19.01-19.50	7W	4
		8W	2
24	19.51-20.00	8W	4

Authorised Distributor :



MKT - 2020

Sales Branch Offices

Pune : +91-8600722264 | Nashik : +91-8600156965 | Bengluru : +91-9590325411 | Chennai : +91-9595832325
Delhi : +91-8010732455 | Kolkata : +91-9903079509 | Gurugram : +91-9555181100 | Gujarat : +91-7820046616